

DETALLE UNION MODULOS TIPO 1

DETALLE PERFILES MODULO TIPO 1

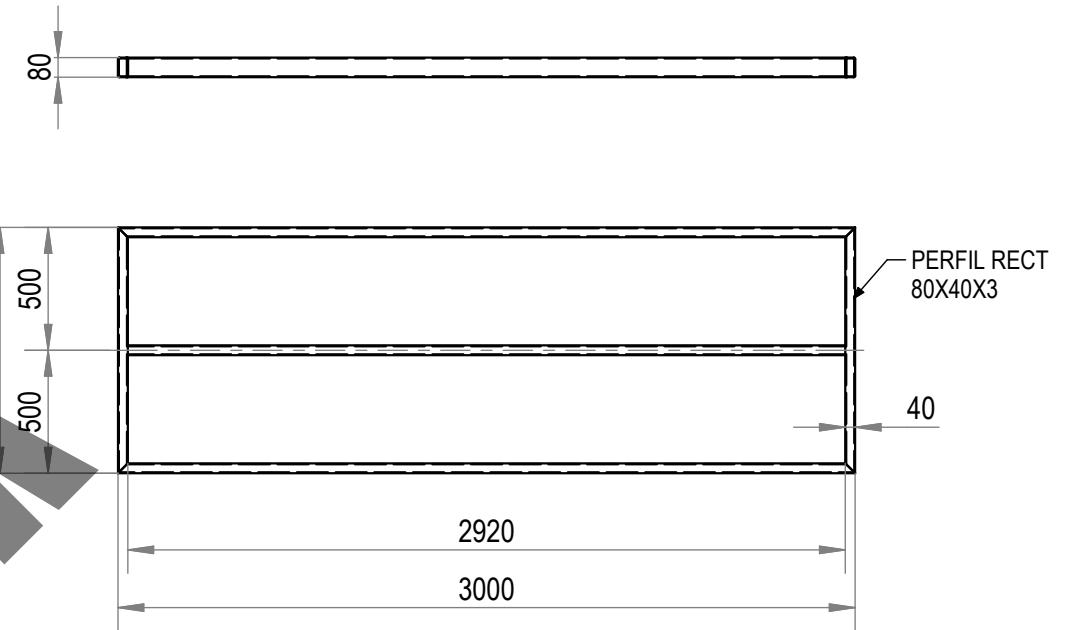

DETALLE - A

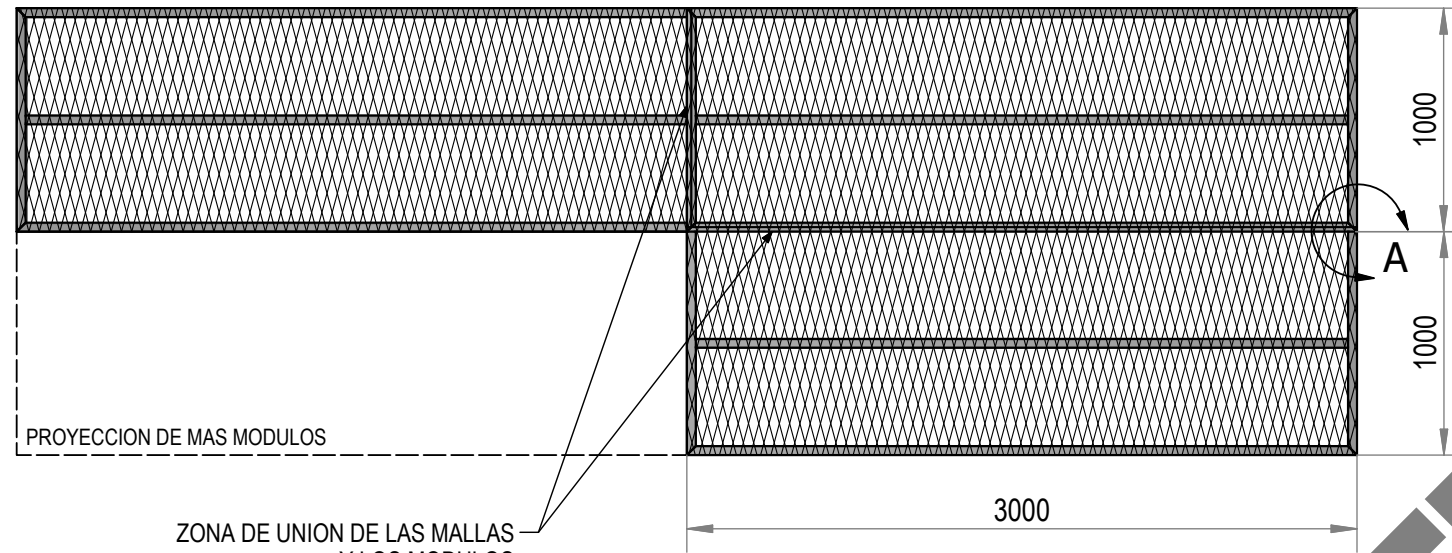
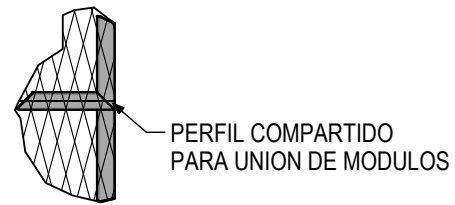

NOTAS:

- Cumple con Norma NCh 1537
- Resistencia 400 kg/m2
- Perfiles Rectangulares 80x40x3 - A. INOX. | AISI 304
- Malla MEDESTUK 62x25x9x3 - A. INOX. | AISI 304L

DETALLE MODULO TIPO 1
Con Malla MEDESTUK 62x25x9x3 A.Inox.

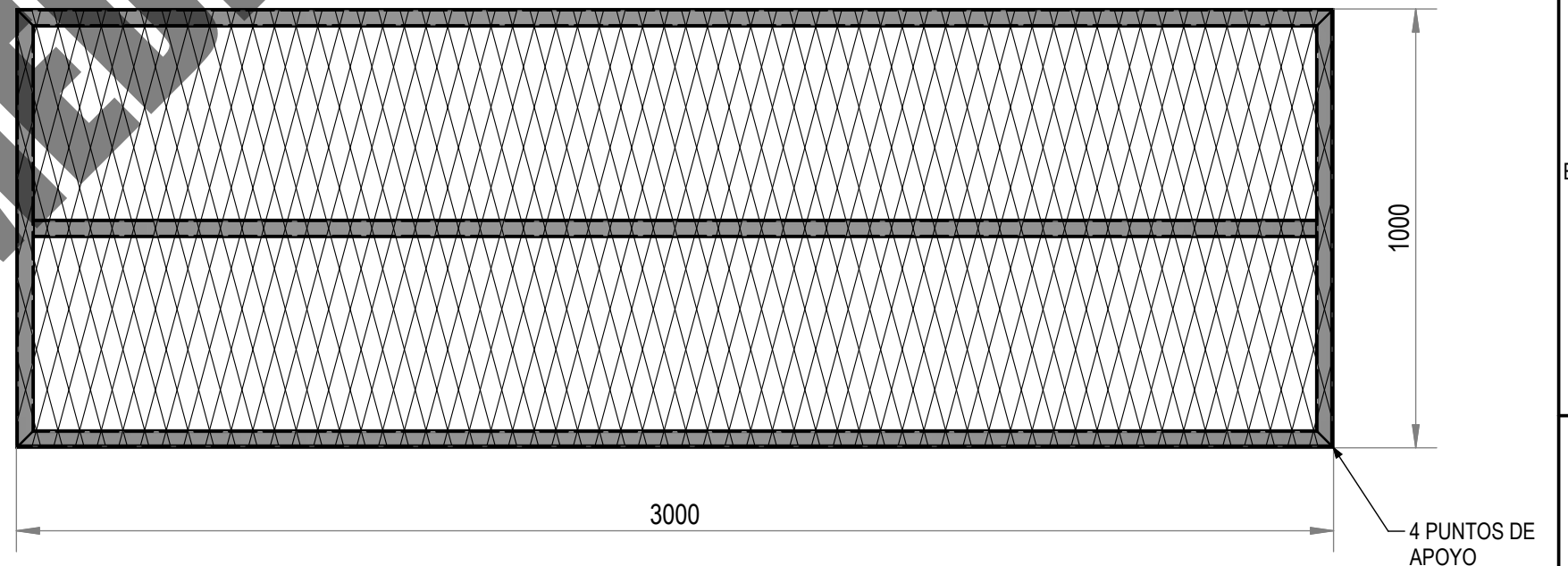
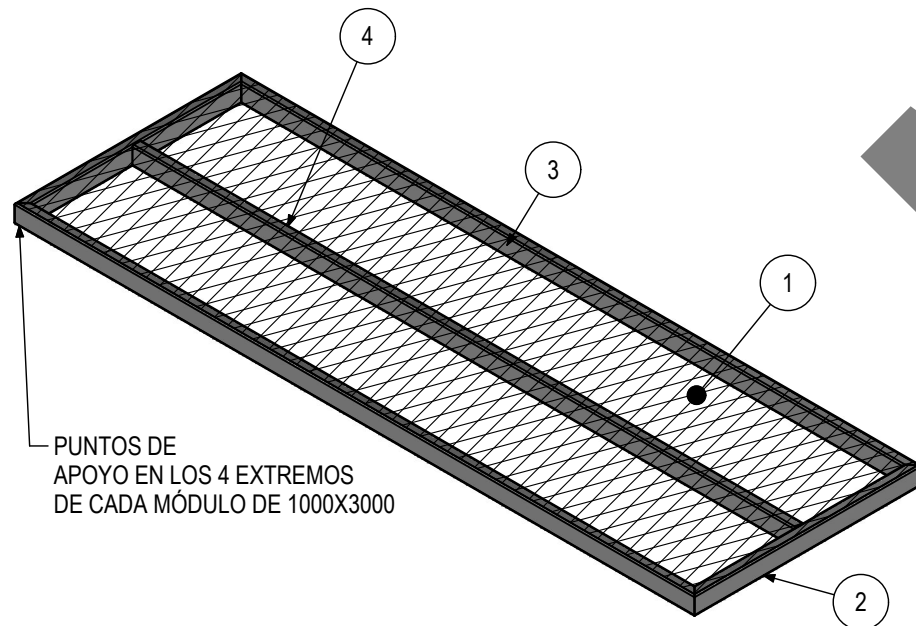

LISTA DE PIEZAS			
ELEMENTO	CTDAD	Nº DE PIEZA	DESCRIPCIÓN
1	1	MALLA MEDESTUK 62X25X9X3 - ANCHO 1000 mm	ACERO INOX.-AISÍ 304L
2	2	PERFIL TUBULAR RECTANGULAR - 80 x 40 x 3 - L= 1000	ACERO INOX.-AISÍ 304
3	2	PERFIL TUBULAR RECTANGULAR - 80 x 40 x 3 - L= 3000	ACERO INOX.-AISÍ 304
4	1	PERFIL RECTANGULAR - 80 x 40 x 3 - L= 2920	ACERO INOX.-AISÍ 304

Diseño de Paola Rodriguez	Revisado por A. ECHAVE	Aprobado por A. ECHAVE	Fecha 22-11-2023	Fecha 22-11-2023
			ESTRUCTURA DE PISO TIPO 1	
			PLANO 1 - PERFILES 80X40X3	Edición 2